

Communications Network

Multiplexing is a method of sending 2 or more signals simultaneously over a single circuit. Multiplexing is used to allow 2 or more electronic modules (nodes) to communicate simultaneously over a twisted-wire pair [data (+) and data (-)] network. The information or messages that can be communicated on these wires consists of commands, status or data. The advantage of using multiplexing is to reduce the weight of the vehicle by reducing the number of redundant components and electrical wiring.

The vehicle has 2 module communication networks which are connected to the Data Link Connector (DLC) , located under the instrument panel on the driver side:

- High Speed Controller Area Network (HS-CAN)
- Medium Speed Controller Area Network (MS-CAN)

The HS-CAN and MS-CAN are defined by various ISO documents:

- ISO 11898 specifies the electrical, mechanical, and procedural interface for Controller Area Network (CAN) serial communication technology.
- ISO 15765 specifies network-layer protocol and timing parameters for CAN -based systems.
- ISO 14229 specifies a common set of unified diagnostics and changes the way PIDs, DTCs and active commands are processed and displayed on the scan tool.

Network Topology

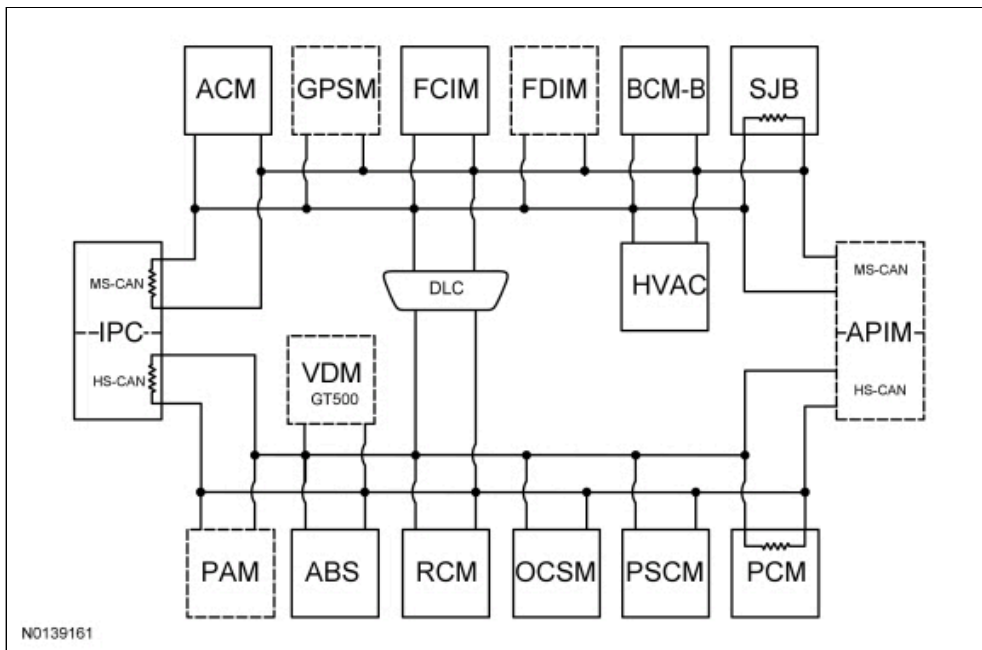

Module Name	Network Type	Termination Module
ABS module	<u>HS-CAN</u>	No
Accessory Protocol Interface Module (APIM) (if equipped)	<u>HS-CAN</u> <u>MS-CAN</u>	No
Audio Front Control Module (ACM)	<u>MS-CAN</u>	No
Body Control Module B (BCM-B)	<u>MS-CAN</u>	No
Front Controls Interface Module (FCIM)	<u>MS-CAN</u>	No
Front Display Interface Module (FDIM) (without navigation)	<u>MS-CAN</u>	No
Global Positioning System Module (GPSM) (if equipped)	<u>MS-CAN</u>	No
HVAC module	<u>MS-CAN</u>	No
Instrument Panel Cluster (IPC) (gateway module)	<u>HS-CAN</u> <u>MS-CAN</u>	Yes Yes
Occupant Classification System Module (OCSM)	<u>HS-CAN</u>	No
Parking Aid Module (PAM)	<u>HS-CAN</u>	No
PCM	<u>HS-CAN</u>	Yes

Module Name	Network Type	Termination Module
Power Steering Control Module (PSCM)	<u>HS-CAN</u>	No
Restraints Control Module (RCM)	<u>HS-CAN</u>	No
Smart Junction Box (SJB)	<u>MS-CAN</u>	Yes
Vehicle Dynamics Module (VDM) (GT500)	<u>HS-CAN</u>	No

Network Termination

The Controller Area Network (CAN) uses network termination to improve communication reliability. Termination modules are located at both ends of the network. As network messages are broadcast in the form of voltage signals, the network voltage signals are stabilized by the termination resistors.

Each termination module has an internal 120 ohm resistor that bridges across the positive and negative bus connection. With two 120 ohm resistors located in a parallel circuit configuration, the total network impedance, or total resistance, is 60 ohms.

Network termination improves bus message reliability by:

- stabilizing bus voltage.
- eliminating electrical interference.

Gateway Module

The IPC is the gateway module, translating messages on the HS-CAN to MS-CAN and vice versa. This allows a message to be distributed throughout both networks.

The IPC is the only module on this vehicle that has this ability.